

Plastic oil level sight

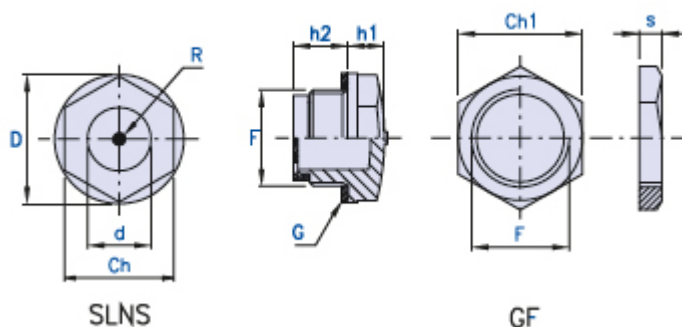

R = Red indicator point
G = Fiber gasket

Code	Dimensions									
	Ch	F	D	d	h1	h2	Nm	Ch1	s	Stock
01SLNS-14	17	G 1/4"	20	15	7	8	8	-	-	-
01SLNS-38	18	G 3/8"	22	14	6,6	10,5	12	19	5	-
01SLNS-12	24	G 1/2"	28	16	8	11	16	27	5	-
01SLNS-34	30	G 3/4"	35	21	8	12	21	32	6	-
01SLNS-1	35	G 1"	43	32	11	12	24	36	6	-
01SLNS-114	42	G 1 1/4"	51	33	10	16	-	46	6	-
01SLNS-112	50	G 1 1/2"	58	40	10	20	-	-	-	-
01SLNS-2	64	G 2"	74	48	12	20	-	-	-	-
01SLNS-14.15	17	M 14x1.5	20	15	7	8	8	-	-	-
01SLNS-16.15	18	M 16x1.5	22	14	6,5	10	12	-	-	-
01SLNS-18.15	21	M 18x1.5	25	16	7	10,5	12	-	-	-
01SLNS-20.15	24	M 20x1.5	28	16	7,5	11	16	-	-	-
01SLNS-40.15	42	M 40x1.5	51	33	10	16	-	-	-	-

Material

Special transparent polyamide resin which provides optimal mechanical resistance performances and a high strength against oils, chemical agents, hydraulic fluids, hydrocarbons, fuels and various solvents.

Asbestos-free fiber flat seal or (upon request) made of (NBR) 70 Shore synthetic rubber.

Description

Hex-head threaded oil level indicator for their hydraulic fluid control on gear reducers, oil tanks and oil chambers in general.

The screwed assembly enables the application even on oil chambers under pressure (max. suggested working pressure 3 bar). The transparent sight glass has a "hot-pressed" red point in the middle.

Assembly

For the assembly it is recommended to follow the data indicated in the table regarding the maximum tightening torque (Nm).

On walls up to 5 mm. thickness it is recommended to use the brass fixing nut code **GF**, which is supplied upon request.

Notes

Maximum suggested working pressure: 3 bar.

Avoid contact with alcohol-based solutions, detergents containing alcohol in general, anti-freeze liquids at high temperature and hot water over 80°C.

Package

SLNS-114/112/2/40.15: 50 pcs.

SLNS-34/1: 50 pcs.

SLNS-14/38/12/14.15/16.15/18.15/20.15: 100 pcs.