

# TN716

## Indexing plunger

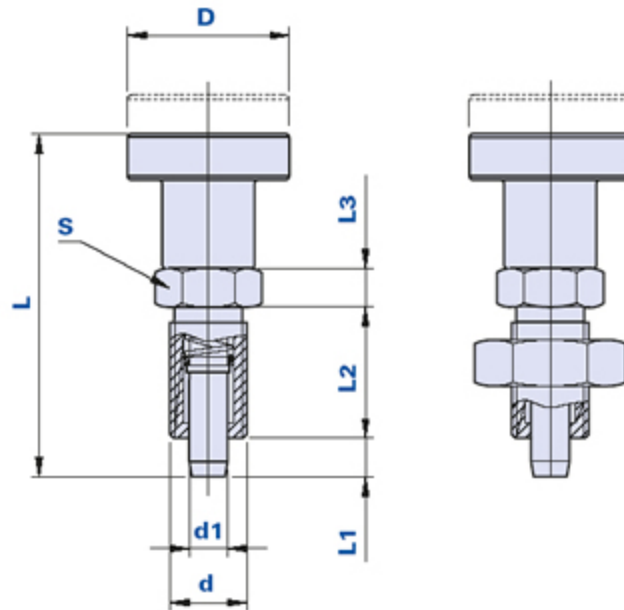

Cod. 021701

Cod. 021701-1



Code	Description	Dimensions								Weight grams	Stock
		D	L	S	d	l1	l2	d1	L3		
0121701	TN716 D.5 M10x1	21	44	12	M10x1	5	17	5	5	17,1	√
0121701-1	TN716-1 D.5 M10x1	21	44	12	M10x1	5	17	5	5	24,7	√

### Knob material

Polyamide-based (PA) technopolymer. Resistant to organic and inorganic chemical substances such as oils, greases, fuels and solvents.

### Metallic body material

Burnished steel. Special executions or in stainless steel on request for suitable quantities.

### Tip material

Hardened, ground and burnished steel. Special executions or in stainless steel on request for suitable quantities.

### Knob colour

Black with satin finish.

### Use

In rest position it locks the rotation or the sliding. By pulling up the knob, the loosening is obtained.

### Remarks

We suggest to make the drilling for the tip with tolerance H7.

### Package

10 - 50 - 100 pcs.

